

**Information required when ordering replacement parts
56,200 Series (rev. A):**

- Give Part Number of parts or kits needed, Brake Model Number, and Brake Serial Number. The Brake Model and Serial Number may identify special brakes not covered by this parts list
- When ordering hubs, specify shaft diameter (hub bore) and keyway.

•Enclosure is specified as follows:

- NEMA 1 (formerly referred to as standard)
- NEMA 4 (formerly referred to as DTWP dust-tight waterproof)
- NEMA 4X (formerly referred to as BISSC washdown)

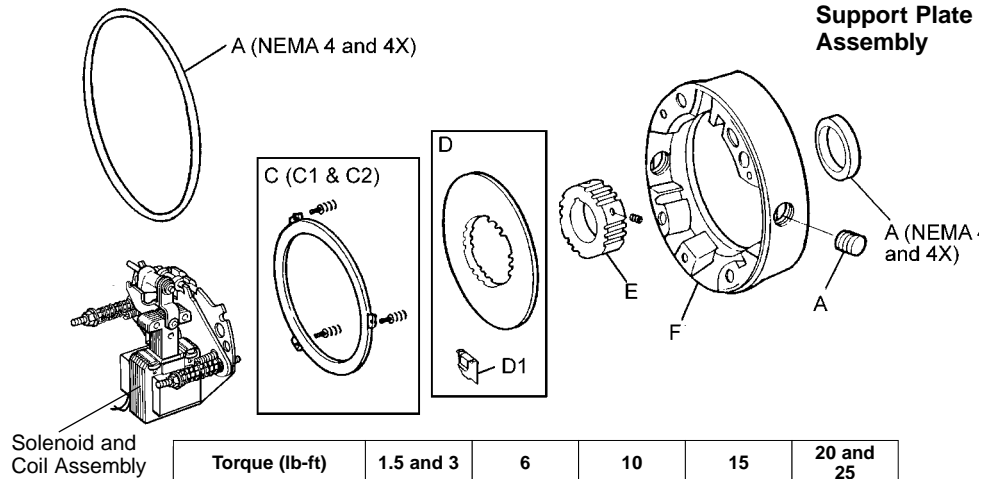
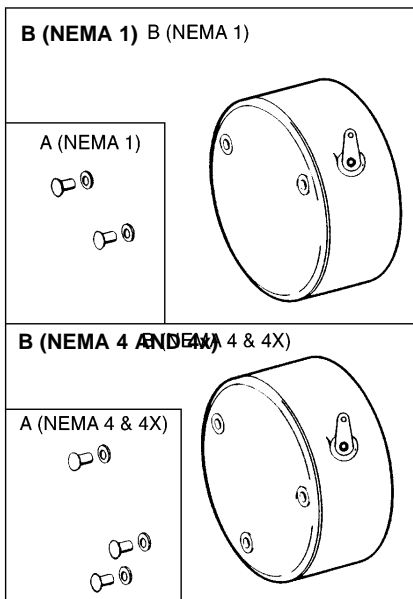

Support Plate Assembly

TABLE 1
Components of Standard AC or DC Brake

Item	Description	Part Number↓	Torque (lb-ft)			1.5 and 3			6			10			15			20 and 25		
			1	4	4X	1	4	4X	1	4	4X	1	4	4X	1	4	4X	1	4	4X
A	Hardware kit - NEMA 1 Hardware kit - NEMA 4 Hardware kit - NEMA 4X	5-66-1014-00 5-66-1015-00 5-66-1013-00	1	1	1	1	1	1	1	1	1	1	1	1	1	1	1	1	1	1
A1	Plug/Gasket kit — NEMA 4 ** Close couple — NEMA 4X — NEMA 4 3 disc — NEMA 4X 3 disc	5-63-0532-00 5-63-0533-00 5-63-0534-00 5-63-0537-00		1	1	1	1	1	1	1	1	1	1	1	1	1	1	1	1	1
B	Housing & release knob kit — NEMA 1 Housing & release knob kit — NEMA 4 Housing & release knob kit — NEMA 4X	5-07-5040-00 5-07-5041-00 5-07-5043-00	1	1	1	1	1	1	1	1	1	1	1	1	1	1	1	1	1	1
C	Stationary disc kit (1 disc universal 3 disc horizontal)	5-66-8354-00	1	1	1	1	1	1	1	1	1	1	1	1	1	1	1	1	1	1
C1	Stationary disc kit (2 disc universal)	5-66-8355-00							1	1	1	1	1	1	1	1	1	1	1	1
C2	Stationary disc kit (3 disc universal)	5-66-8356-00																1	1	1
Not Shown	Vertical spring kit (3 disc)	5-63-0525-00																1	1	1
D	Friction disc kit	5-66-8462-00	1	1	1	1	1	1	1	2	2	2	2	2	2	2	2	3	3	3
D1	Stabilizing spring	8-161-505-00	2	2	2	2	2	2	2	*	*	*	*	*	*	*	*	*	*	*
DP	Disc pack kit — 1 disc Disc pack kit — 2 disc Disc pack kit — 3 disc	5-66-8601-00 5-66-8602-00 5-66-8603-00	1	1	1	1	1	1	1	1	1	1	1	1	1	1	1	1	1	1
E	Hub and set screw assembly 1 & 2 disc (NEMA 1)	5/8 bore 5-16-5150-00-01B 7/8 bore 5-16-5150-00-01D 1-1/8 bore 5-16-5150-00-01E	1			1			1			1		1						
	Hub and set screw assembly 1 disc (NEMA 4 & 4X)	5/8 bore 5-16-5151-00-01B 7/8 bore 5-16-5151-00-01D 1-1/8 bore 5-16-5151-00-01E		1	1		1	1												
	Hub and set screw assembly 3 disc (NEMA 1) and 2 & 3 disc (NEMA 4 & 4X)	5/8 bore 5-16-5153-00-01B 7/8 bore 5-16-5153-00-01D 1-1/8 bore 5-16-5153-00-01E								1	1	1	1	1	1	1	1	1	1	1
F	Endplate	1 disc (NEMA 1)	1			1			1			1								
	Endplate	2 & 3 disc (NEMA 1)																1		
	Endplate & Seal Assy.	1 disc (NEMA 4)		1		1														
	Endplate & Seal Assy.	2 & 3 disc (NEMA 4)								1				1						
F	Endplate & Seal Assy.	1 disc (NEMA 4X)																		
	Endplate & Seal Assy.	2 & 3 disc (NEMA 4X)																		1

* Certain multiple friction disc model numbers require a single stabilizer clip (D1) added to each friction disc. If your brake has these clips, they must be replaced when the friction disc is replaced. This clip is included as part of the friction disc kit 5-66-8462-00.

** Close coupled brakes identified by 8 in the 8th digit. example: 1-056-XXX-8X.

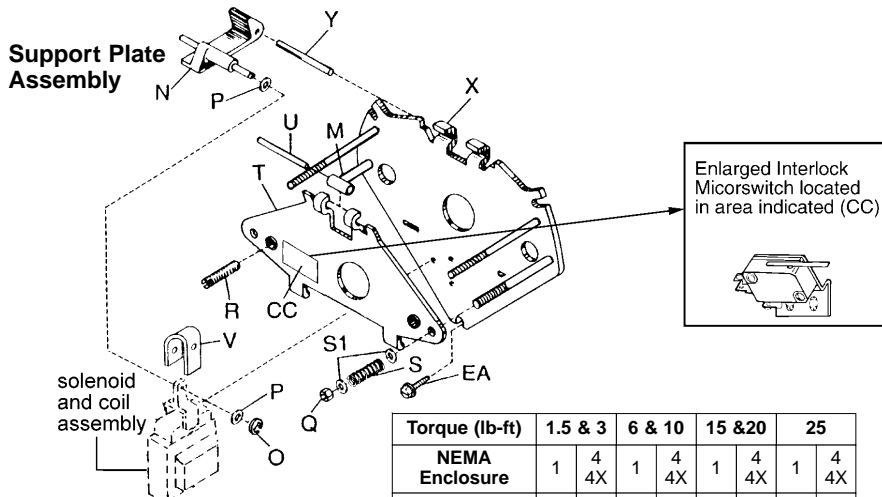

TABLE 2
Components of Support Plate and Coil Assembly

Item	Description	Part Number	Torque (lb-ft)							
			1.5 & 3		6 & 10		15 & 20		25	
NEMA Enclosure			1	4 4X	1	4 4X	1	4 4X	1	4 4X
Support Plate Assy. (Items M through Y and EA)→			5-42-5561-00	5-42-5562-00	5-42-5563-00	5-42-5564-00	5-42-5565-00	5-42-5566-00	5-42-5565-00	5-42-5566-00
M	Bearing	8-006-501-00	1	1	1	1	1	1	1	1
N	Solenoid lever	8-008-504-01	1	1	1	1	1	1	1	1
O	Retaining ring	9-03-0057-00	1	1	1	1	1	1	1	1
P	Spacer	9-45-0168-00	2	2	2	2	2	2	2	2
Q	Torque adjustment nut	9-40-3928-00	2	2	2	2	2	2	2	2
R	Wear adjustment screw	8-100-507-00	2	2	2	2	2	2	2	2
S	Pressure spring	9-70-1215-00	2	2						
	Pressure spring	9-70-1523-00			2	2				
	Pressure spring	9-70-1524-00					2	2	2	2
S1	Spring washer	9-46-0010-00			4	4	4	4	4	4
T	Lever arm and stop nut assy.	5-17-5011-00	1	1	1	1	1	1	1	1
U	Bearing pin	9-29-4826-00	1	1	1	1	1	1	1	1
V	Plunger stop	8-094-503-00	1	1	1	1	1	1	1	1
X	Support plate and spring stud assembly (2 housing studs)	5-26-5019-00	1		1		1		1	
	Support plate and spring stud assembly (3 housing studs)	5-26-5020-00		1		1		1		1
Y	Pivot pin	9-29-4836-00	1	1	1	1	1	1	1	1
EA	Mounting screws	9-25-9013-00	3	3	3	3	3	3	3	3

AC Brakes

Item	Description	Part Number	1.5 & 3	6 & 10	15 & 20	25	
Z	No. 4 solenoid kit	5-66-5042-00	1	1	1	1	
AA	No. 4 coil kit 60 Hz	115-230 Vac	5-66-6407-33	1			
		230/460 Vac	5-66-6409-33	1			
		115 Vac	5-66-6401-33	1			
		230 Vac	5-66-6402-33	1			
		460 Vac	5-66-6404-33	1			
	575 Vac	5-66-6405-33	1				
	No. K4 coil kit 60 Hz	115-230 Vac	5-66-6457-33		1		
		230/460 Vac	5-66-6459-33		1		
		115 Vac	5-66-6451-33		1		
		230 Vac	5-66-6452-33		1		
		460 Vac	5-66-6454-33		1		
	575 Vac	5-66-6455-33		1			
	No. K4 + coil kit 60 Hz	115-230 Vac	5-66-6407-23			1	
		230/460 Vac	5-66-6409-23			1	
		115 Vac	5-66-6401-23			1	
		230 Vac	5-66-6402-23			1	
		460 Vac	5-66-6404-23			1	
	575 Vac	5-66-6405-23			1		
	No. M4 + coil kit 60 Hz	115-230 Vac	5-66-6457-23				1
		230/460 Vac	5-66-6459-23				1
115 Vac		5-66-6451-23				1	
230 Vac		5-66-6452-23				1	
460 Vac		5-66-6454-23				1	
575 Vac	5-66-6455-23				1		
CC	Brake release interlock switch (optional)	5-57-5526-00	1	1	1	1	

DC Brakes

Item	Description	Part Number	1.5 & 3	6 & 10	15 & 20	25
AB	No. 4 + coil assembly	115 Vdc 230 Vdc	5-96-6416-43 5-96-6417-43	1 1		
	No. K4 + coil assembly	115 Vdc 230 Vdc	5-96-6416-23 5-96-6417-23		1 1	
	No. M4 + coil assembly	115 Vdc 230 Vdc	5-96-6466-23 5-96-6467-23			1 1
	No. P4 + coil assembly	115 Vdc 230 Vdc	5-96-6446-43 5-96-6447-43			1 1
BB	Electronic DC switch kit	24/28 Vdc	5-57-5712-15			
		115 Vdc	5-57-5716-15			
		230 Vdc	5-57-5717-15			

Solenoid and Coil Assembly

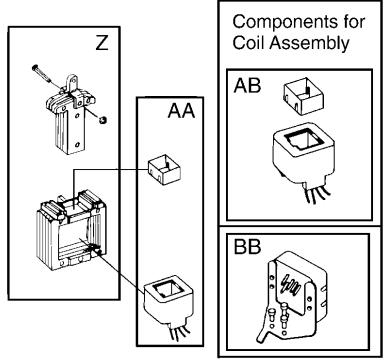

TABLE 3
Contents of Kits and Assemblies

Item	Kit Description
A	Hardware kit – NEMA 1 (5-66-1001-00) 2 – Housing acorn nuts 2 – Conduit plugs
	Hardware kit – NEMA 4 (5-66-1002-00) Hardware kit – NEMA 4X (5-66-1003-00) 3 – Housing nuts 3 – Housing nut gaskets 1 – Endplate oil seal 2 – Endplate hole plugs 2 – Housing to endplate “U” gasket 2 – Endplate conduit pipe plugs
B	Housing & release knob kit (5-66-875X-00) 1 – Housing and release knob assembly 2 or 3 – Housing nuts 3 – Housing nut gasket (NEMA 4 and 4X)
C	Stationary disc kit (5-66-8355-00) 1 – Stationary disc
C1	Stationary disc kit (5-66-8354-00) 2 – Stationary discs with springs
C2	Stationary disc kit (5-66-8356-00) 3 – Stationary discs with springs
D	Friction disc kit (5-66-8462-00) 1 – Friction disc 2 – Stabilizing springs (for 1-1/2 lb-ft brake use only)
DP	Disc pack kit (5-66-860X-00) 1, 2 or 3 – Friction disc(s) 1, 2 or 3 – Stationary disc(s) 2 – Stabilizing springs (for 1-1/2 lb-ft brake use only) 3, 6 or 9 – Stationary disc separator springs
E	Hub and screw assembly – all types, all bores (5-16-515X-00) 1 – Brake hub 2 – Set screws
Z	No. 4 solenoid kit (5-66-5042-00) 1 – Plunger 1 – Solenoid link 1 – Frame 1 – Solenoid link cap screw 1 – Solenoid link nut 3 – Solenoid mounting screws
AA AB	No. 4 AC coil kit (5-66-64-XX-X3) and DC coil assembly (5-96-64XX-X3) Coil / Top Plunger guide / Wire nut
BB	DC switch kit (5-57-571X-15) 1 – Electronic switch 1 – Mounting bracket 3 – Bracket mounting screws 4 – Switch mounting screws 4 – nuts 4 – Lock washers 5 – Crimp connectors
	Brake release interlock switch (5-57-5526-00) 1 – Microswitch 1 – Mounting bracket 2 – Bracket mounting screws 2 – Switch mounting screws 2 – Lock washers 2 – Nuts 2 – Lead wire assembly



Rexnord Industries, Inc.
Stearns Division
5150 S. International Drive
Cudahy, Wisconsin 53110
(414) 272-1100 Fax: (414) 277-4364 www.rexnord.com