

Installation, Service and Parts List for Series 56,700 (rev. A) Double C-Face Coupler

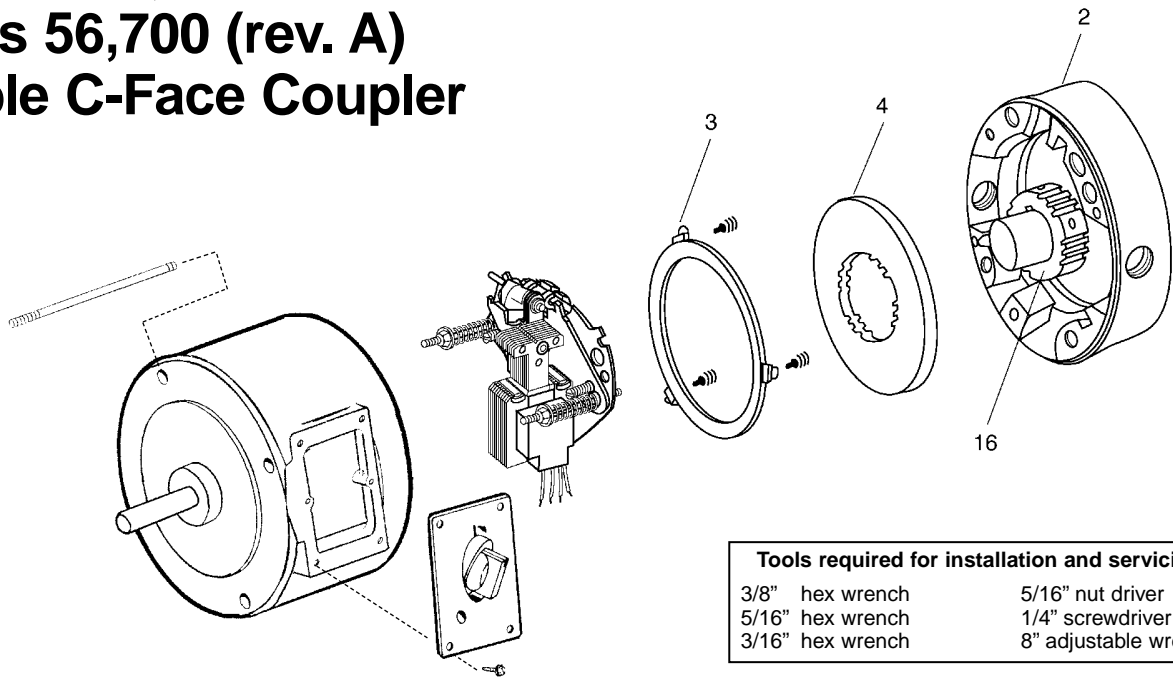

Tools required for installation and servicing:

3/8" hex wrench	5/16" nut driver
5/16" hex wrench	1/4" screwdriver
3/16" hex wrench	8" adjustable wrench

Typical Nameplate

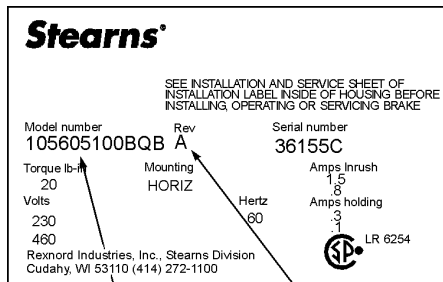

Note:

MODEL NUMBER will appear on brake nameplate.

REVISION CONTROL (if applicable) and brake serial number

Important

Please read these instructions carefully before installing, operating, or servicing your Stearns Brake. Failure to comply with these instructions could cause injury to personnel and/or damage to property if the brake is installed or operated incorrectly. For definition of limited warranty/liability, contact Rexnord Industries, Inc., Stearns Division, 5150 S. International Dr., Cudahy, WI 53110, (414) 272-1100.

Caution

1. Installation and servicing must be made in compliance with all local safety codes including Occupational Safety and Health Act (OSHA). All wiring and electrical connections must comply with the National Electric Code (NEC) and local electric codes in effect.

2. Do not install the brake in atmospheres containing explosive gases or dusts.
3. To prevent an electrical hazard, disconnect power source before working on the brake. If power disconnect point is out of sight, lock disconnect in the *off* position and tag to prevent accidental application of power.
4. Make certain power source conforms to the requirements specified on the brake nameplate.
5. Be careful when touching the exterior of an operating brake. Allow sufficient time for brake to cool before disassembly. Surfaces may be hot enough to be painful or cause injury.
6. Do not operate brake with housing removed. All moving parts should be guarded.
7. Installation and servicing should be performed only by qualified personnel familiar with the construction and operation of the brake.
8. For proper performance and operation, only genuine Stearns parts should be used for repairs and replacements.
9. After usage, the brake interior will contain burnt and degraded friction material dust. This dust must be removed before servicing or adjusting the brake.

DO NOT BLOW OFF DUST using an air hose. It is important to avoid dispersing dust into the air or inhaling it, as this may be dangerous to your health.

- a) Wear a filtered mask or a respirator while removing dust from the inside of a brake.
- b) Use a vacuum cleaner or a soft brush to remove dust from the brake. When brushing, avoid causing the dust to become airborne. Collect the dust in a container, such as a bag, which can be sealed off.

General Description

The 56,700 Series coupler is a spring-set, electronically released brake, containing either one or more rotating friction discs (4) driven by a hub (16) mounted on the motor shaft. The double C-face allows the brake to directly couple a C-face motor to a C-face gear reducer.

Caution! While the brake is equipped with a manual release to allow manual shaft rotation, the motor should not be run with the manual release engaged, to avoid overheating the friction disc(s).

Caution! Do not apply overhung or die load to brake output shaft.

BRAKE MOUNTING FOR 56,700 COUPLER

1 Place hub on motor shaft.

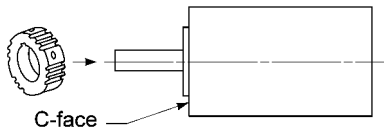

2 Place hub on shaft as shown. Insert key (provided) until it is flush with end of motor shaft.

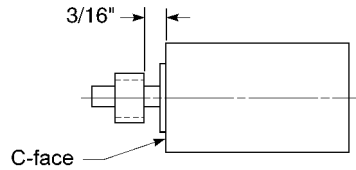

Note: Minimum key length is 1.57".

3 Tighten set screws to motor shaft.

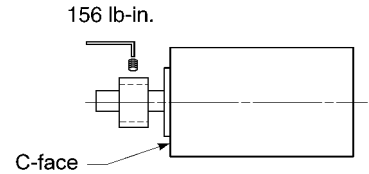

4 A. Remove housing nuts and slide tie bolt out of brake.
B. Remove housing from endplate.

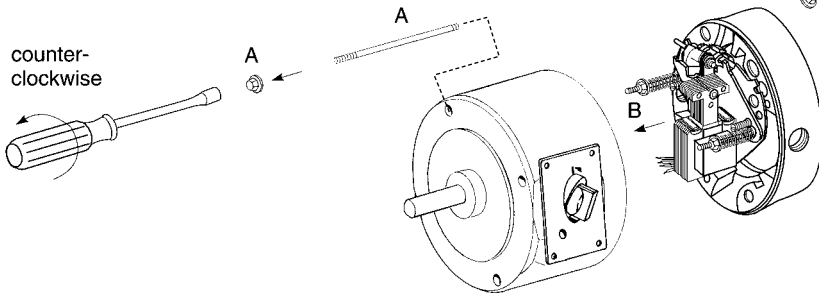

5 Slide endplate over hub noting position of stabilizer springs, if used. (Refer to friction disc replacement; view 5).

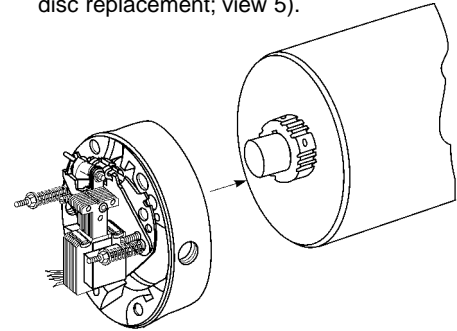

6 Mount brake endplate to motor C-face.* using the four tie bolts. Finger tighten.

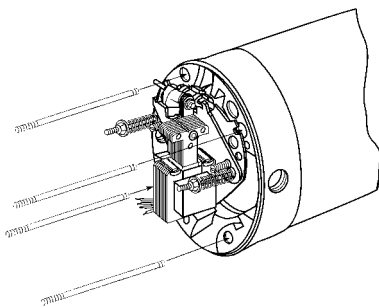

* For vertical assembly of 20 & 25 lb-ft brakes refer to page 5.

7 Connect coil leadwires to power supply. Refer to nameplate for voltage rating. **Caution:** Keep wiring away from pinch points and moving components.

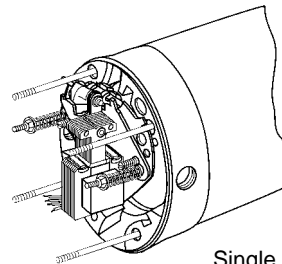
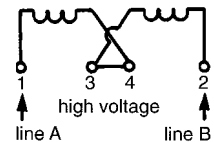
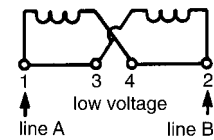

Single voltage coil - connect direct to power supply.

For	Power Line A	Power Line B	Tie Leads
Low Voltage	1 and 3	2 and 4	-
High Voltage	1	2	3 and 4

8 A. Slide housing and shaft assembly onto mounting studs, rotating shaft until keyway is aligned. Be sure housing is assembled with access windows in same position as shown in Figure 1, page 1.
B. Mount and secure brake/motor assembly to C-face mounting register of reducer. Using four 3/8 - 16 nuts and lockwashers, tighten to 30-35 ft-lb.

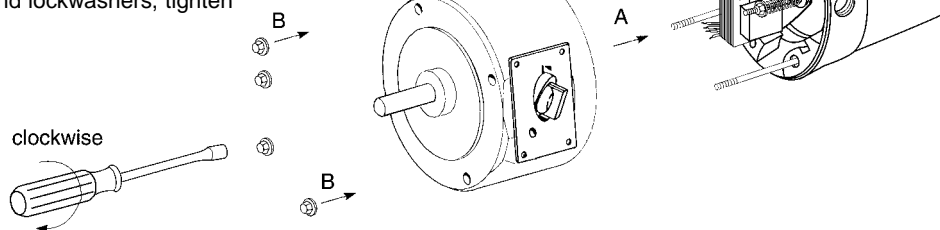

FRICION DISC REPLACEMENT

Series 56,700

- 1** A. Remove four mounting nuts and lockwashers.
B. Slide motor/brake assembly from mounting register of reducer.

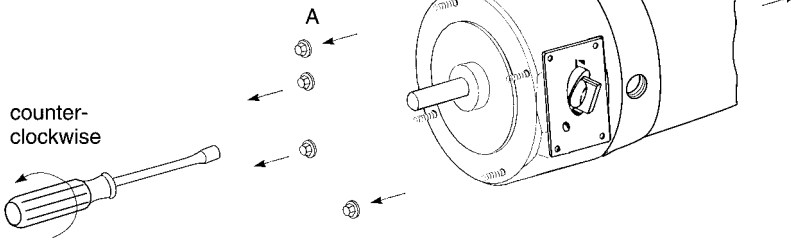

- 2** Slide housing and shaft assembly off the mounting studs.

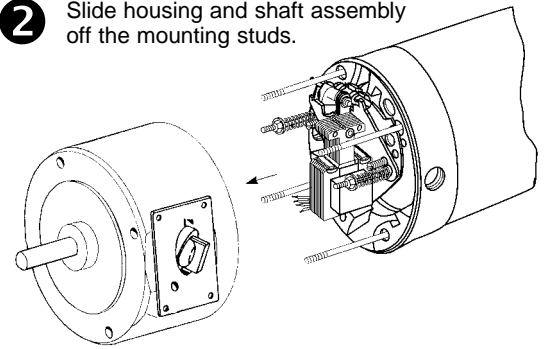

- 3** Remove 3 support plate screws and lift support plate from brake.

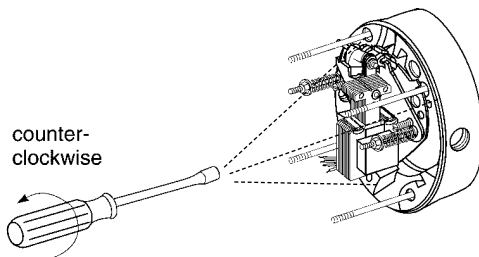

- 4** Remove and discard old friction disc(s).

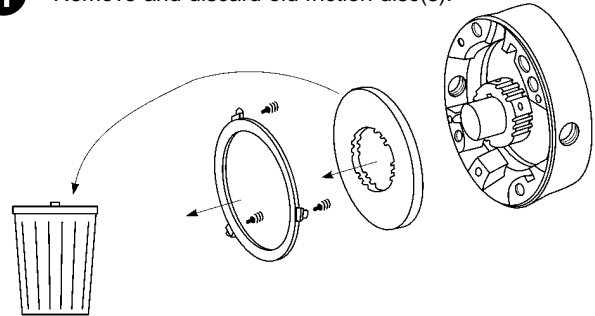

- 5** Install new friction disc(s) and stationary disc(s) as shown.

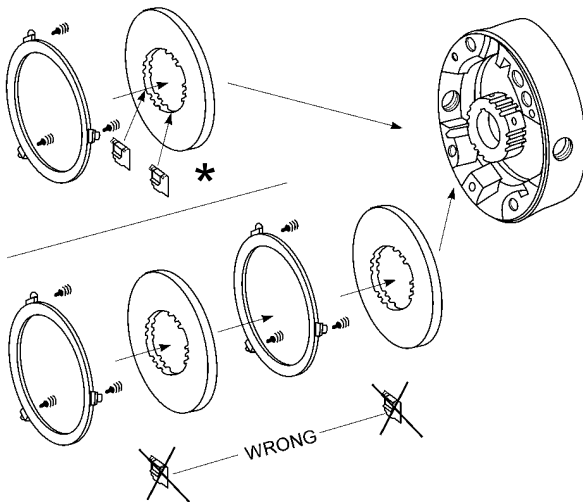

5A

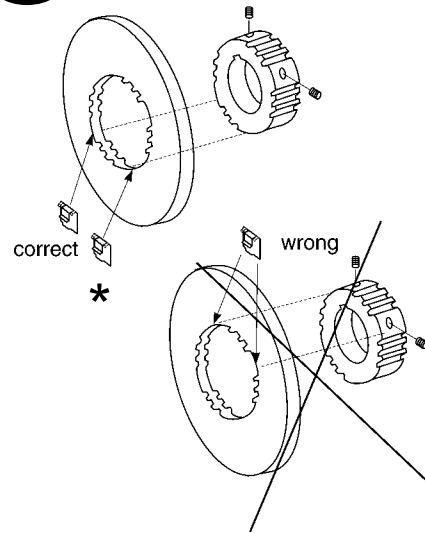

* Stabilizer springs are for use on single disc units only. Position springs opposite set screw holes.

*For brakes with vertical springs see page 5.

- 6** Reposition support plate on endplate and retighten mounting screws to 55 in-lb.

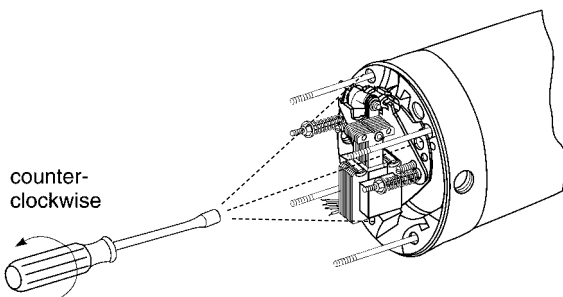

- 7** Reassemble housing and mount to reducer following step 8, brake mounting procedure.

AIR GAP ADJUSTMENT

Series 56,700

As friction discs wear the air gap will increase. When plunger gets to the reset position, the air gap must be adjusted.

- 1** To increase air gap, equally turn adjusting screws (10) counterclockwise.

Air Gap Settings*

Torque (lb-ft)	56,X00 Series
1.5, 3 & 6	.385" ± .030"
10 & 15	.450" ± .030"
20 & 25	.500" ± .030"

*For reference only

- 2** To decrease air gap, equally turn adjusting screws (10) clockwise.

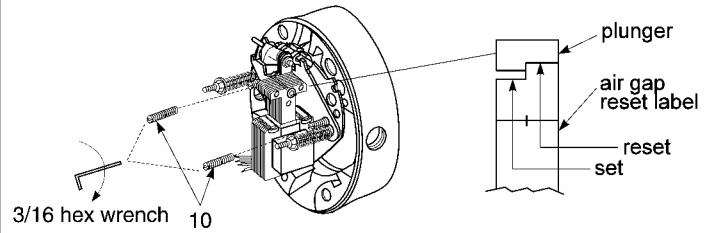
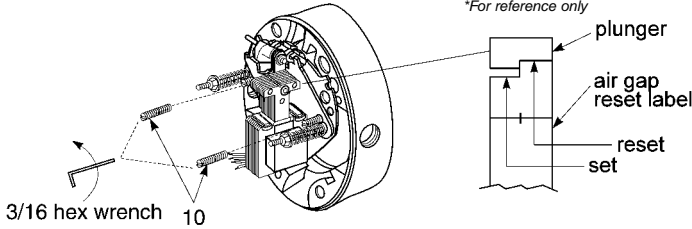

Note: Air gap can be adjusted without disassembly. Remove cover plate (7A) and manual release plate (7B) and adjust as shown above.

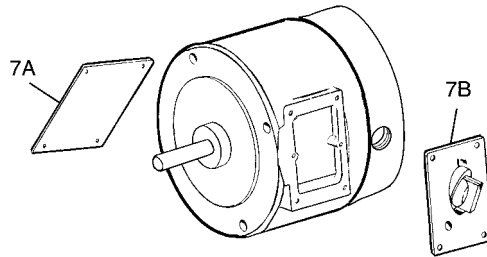

COIL REPLACEMENT

Series 56,700

- 1** A) Remove four mounting nuts and lockwashers.
B) Slide motor/brake assembly from mounting register of reducer.

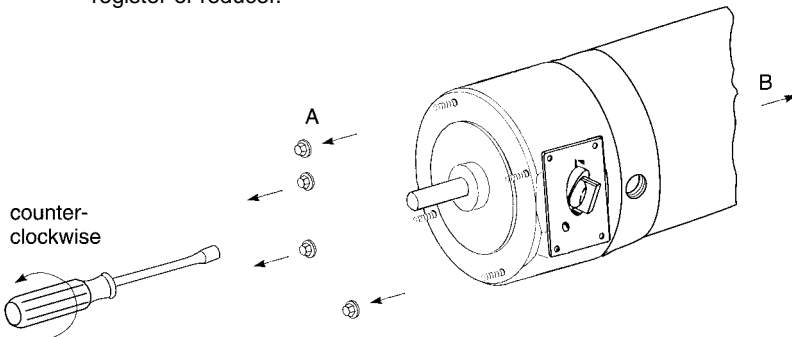

- 2** Slide housing and shaft assembly off the mounting studs.

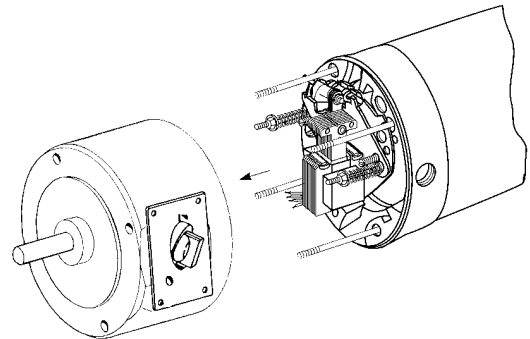

- 3** Disconnect coil leadwires from power source.

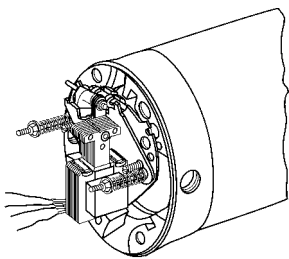

- 4** Insert screwdriver between support plate and lever arm and pry forward.

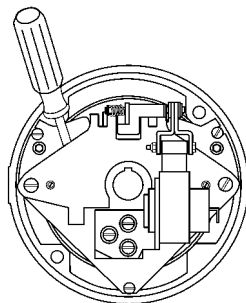

- 5** Lift plunger/solenoid lever assembly out of coil.

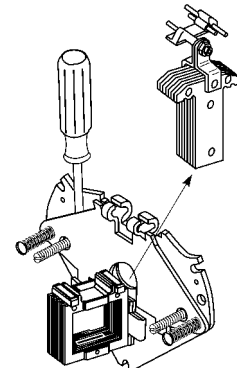

6 Remove plunger guide.

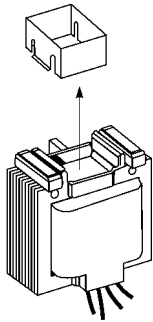

7 Remove and discard coil.

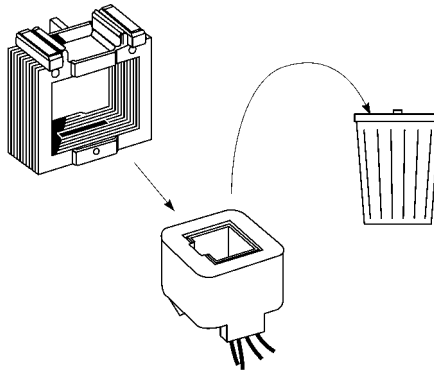

8 A. Insert new coil. (Lead wires in same position as old coil.)
B. Insert plunger guide.

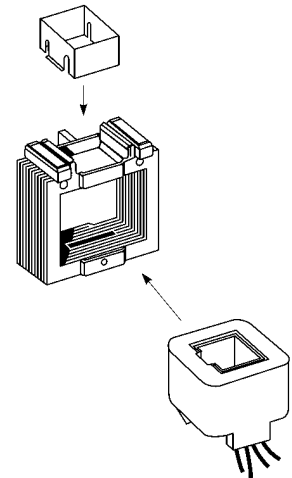

9 Reinsert plunger into coil; drop pivot pin into cradle of support plate. Remove screwdriver.

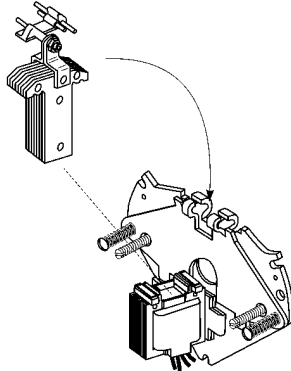

10 Connect coil leadwires to power supply. Refer to nameplate for voltage rating.

Caution: Keep wiring away from pinch points and moving components.

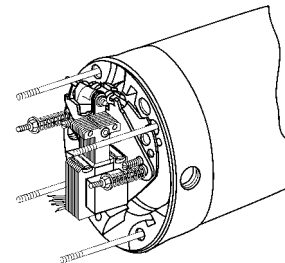
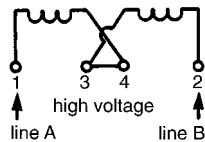
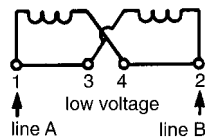

Single voltage coil-connect direct to power supply.

For	Power Line A	Power Line B	Tie Leads
Low Voltage	1 and 3	2 and 4	—
High Voltage	1	2	3 and 4

11 A. Slide housing and shaft assembly onto mounting studs, rotating shaft until keyway is aligned. Be sure housing is assembled with access windows in same position as shown in Figure 1, page 1.
B. Mount and secure brake/motor assembly to C-face mounting register of reducer. Using four 3/8 - 16 nuts and lockwashers, tighten to 30-35 ft-lb.

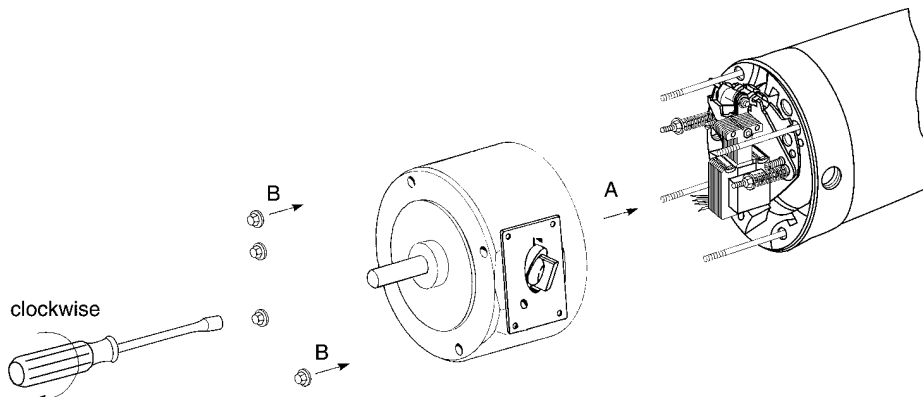

Vertical Brake Assembly

Single disc brakes (1.5, 3 & 6 lb-ft) are universal mount and do not require separator springs. Double disc brakes (10 & 15 lb-ft.) universal mount but require separator springs which are preassembled to the stationary disc. These discs are inserted spring first into the brake. Refer to figure 5A below.

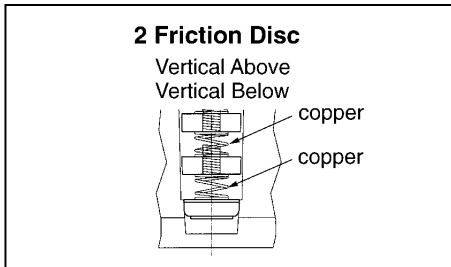

Figure 5A

Installation Procedure for 20 and 25 lb-ft brakes if mounted vertical to motor shaft (These brakes are factory assembled for horizontal operation.)

Remove support plate by loosening the three mounting screws.

Remove stationary discs and friction discs.

Using the spring kit provided with this brake, insert three springs of identical color into each stationary disc hole. Springs are inserted from the side opposite the indent mark (see Figure 5B). Stationary disc should be placed on a clean flat surface with a clearance hole to allow the tip of the spring to extend through the bottom side of the support plate. Using the 1/8" pin provided and a hammer, drive the hold until the large coil diameter bottoms out against the disc.

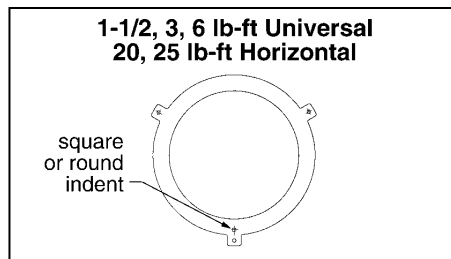

Figure 5B

Reassemble the disc pack with the stationary discs in the proper arrangement shown in Figure 5C.

Mount support plate and torque screws evenly to 55 in-lbs.

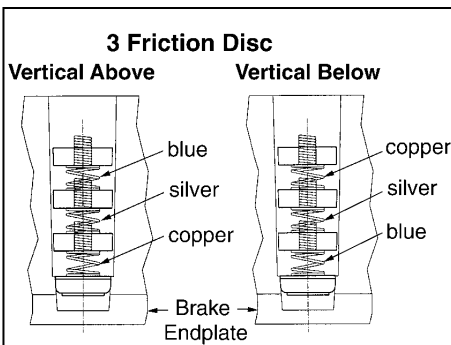

Figure 5C

Torque Adjustment

Brake is factory set for nominal rated static torque which is maximum torque. Torque may be decreased up to 50% for increased stopping times up to 2 second stop time.

The torque on the 1-1/2 lb-ft brake may not be reduced.

Turn both adjustment nuts (11), Figure 6, equal amounts counterclockwise to decrease torque. See Table A for torque reduction permissible amounts.

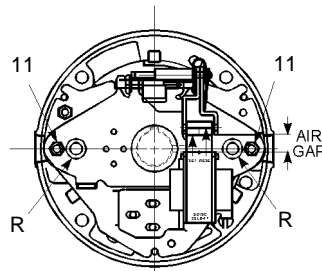

Figure 6

TABLE A

Nominal Static Torque (lb-ft)	Original Spring Height (inches)	Maximum Counterclockwise Turns	% Torque Reduction per Turn
1-1/2	1-13/16	-	-
3	1-1/2	5-1/2	9%
6	1-1/2		
10	1-9/16		
15	1-9/16		
20	1-9/16		
25	1-1/2		

General Maintenance

Warning! Any mechanism or load held in position by the brake should be secured to prevent possible injury to personnel or damage to equipment before any disassembly of the brake is attempted or before the manual release knob is operated on the brake.

Observe all cautions listed at the beginning of this manual before attempting to service brake.

Troubleshooting

A. If brake does not stop properly or overheats, check the following:

1. Are friction discs excessively worn, charred, or broken?
2. Hub may have become loose and shifted on shaft. Recheck set screw torque. Reposition hub if shifted.
3. With brake de-energized and housing (7) removed, check compressed length of pressure springs (11). Compare to Table values (at right) and adjust to minimum height to obtain desired stop times.
4. Is solenoid air gap adjusted correctly? See Page 3 for instructions.
5. Solenoid may not be energizing and releasing the brake. Check voltage at the coil and compare to the coil and/or nameplate voltage rating.

6. Check linkage for binding. Depress solenoid plunger down to frame surface. Movement to be without binding.
7. Brake coil should be energized at same time or prior to energization of motor, and de-energized at same time or after de-energization of motor.
8. Replace friction disc(s) when worn area is one half of original 3/16" thickness.
9. Check to be sure wear adjust screws are of equal height. Measure from inboard side of support plate with depth micrometer. Turn one screw to obtain equal height.

B. If solenoid hums, pulls in slowly, or coil burns out, check the following:

1. Solenoid plunger to frame contact surface may be excessively dented.
2. Are solenoid plunger to frame contact surfaces sticky and dirty.
3. Solenoid mounting screws may have become loose, causing frame to shift and plunger to seat improperly.

Information required when ordering replacement parts:

- Give part number of parts or kits needed, brake model number, and brake serial number. The brake model and serial number may identify special brakes not covered by this parts list.
- When ordering hubs, specify shaft diameter (hub bore) and keyway.
- Enclosure is specified as follows:

NEMA 1 (formerly referred to as standard)
 NEMA 4 (formerly referred to as DTWP dust-tight waterproof)
 NEMA 4X (formerly referred to as BISSC washdown)

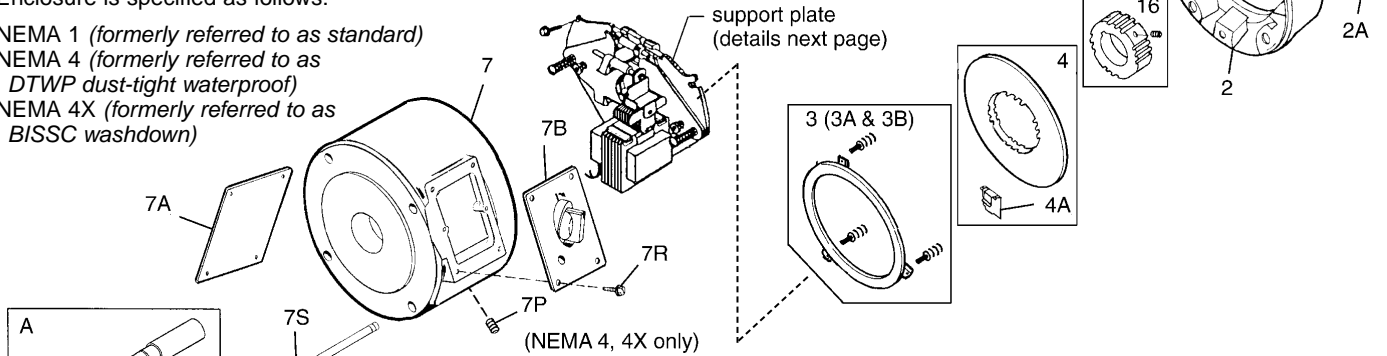
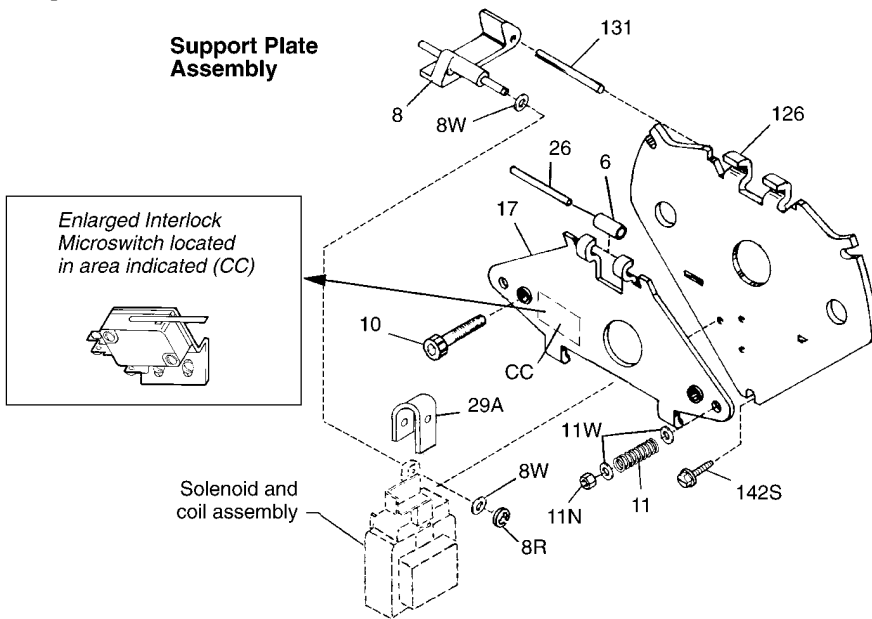

TABLE 1
 Components of Standard AC or DC Brake

Item	Description	Part Number→	Torque (lb-ft)		1.5 & 3						6						10						15						20 & 25					
			Current		AC		DC		AC		DC		AC		DC		AC		DC		AC		DC		AC		DC							
			NEMA Enclosure		2	4X	2	4	2	4	2	4	2	4	2	4	2	4	2	4	2	4	2	4	2	4	2	4						
	Brake Model Number↓		1-056-701-00 & 711-00	1-056-702-00 & 712-00	1-056-704-00 & 714-00	1-056-705-00 & 715-00	1-056-706-00 & 716-00	1-056-708-00 & 718-00	1-056-721-00	1-056-722-00	1-056-724-00	1-056-725-00	1-056-726-00	1-056-728-00	1-056-731-00	1-056-732-00	1-056-734-00	1-056-735-00	1-056-736-00	1-056-738-00	1-056-741-00	1-056-742-00	1-056-744-00	1-056-745-00	1-056-746-00	1-056-748-00	1-056-751-00 & 761-00	1-056-752-00 & 762-00	1-056-754-00 & 764-00	1-056-755-00 & 765-00	1-056-756-00 & 766-00	1-056-758-00 & 768-00		
A	Coupler brake shaft kit (5/8 diameter) Coupler brake shaft kit (7/8 diameter) Coupler brake shaft kit - 3 disc (7/8 dia.)	5-66-8865-00 5-66-8867-00 5-66-8869-00	1	1	1	1	1	1	1	1	1	1	1	1	1	1	1	1	1	1	1	1	1	1	1									
7	Housing - standard (NEMA 2) Housing - DTWP (NEMA 4) Housing - BISSC (NEMA 4X)	8-007-527-09 8-007-527-11 8-007-527-12	1	1	1	1	1	1	1	1	1	1	1	1	1	1	1	1	1	1	1	1	1	1	1	1	1	1	1	1	1			
7S	Mounting stud	9-09-0010-00	4	4	4	4	4	4	4	4	4	4	4	4	4	4	4	4	4	4	4	4	4	4	4	4	4	4	4	4	4			
7A	Access cover (NEMA 2) Access cover (NEMA 4) Access cover (NEMA 4X)	8-104-505-00 8-104-506-00 8-104-506-01	1	1	1	1	1	1	1	1	1	1	1	1	1	1	1	1	1	1	1	1	1	1	1	1	1	1	1	1	1			
7B	Manual release assembly (NEMA 2) Manual release assembly (NEMA 4) Manual release assembly (NEMA 4X)	5-07-5033-00 5-07-5037-00 5-07-5038-00	1	1	1	1	1	1	1	1	1	1	1	1	1	1	1	1	1	1	1	1	1	1	1	1	1	1	1	1	1			
7R	Machine screw	9-25-7321-00	4	12	12	4	12	12	4	12	12	4	12	12	4	12	12	4	12	12	4	12	12	4	12	12	4	12	12	4	12			
not shown	Release Knob Kit	5-63-5503-00	1	1	1	1	1	1	1	1	1	1	1	1	1	1	1	1	1	1	1	1	1	1	1	1	1	1	1	1				
not shown	Gasket - access cover (NEMA 4) Gasket - access cover (NEMA 4X)	8-073-504-00 8-073-505-00	2	2	2	2	2	2	2	2	2	2	2	2	2	2	2	2	2	2	2	2	2	2	2	2	2	2	2	2	2			
not shown	Gasket - housing to endplate (NEMA 4) Gasket - housing to endplate (NEMA 4X)	8-069-506-00 8-069-511-00	1	1	1	1	1	1	1	1	1	1	1	1	1	1	1	1	1	1	1	1	1	1	1	1	1	1	1	1	1			
not shown	Gasket - brake ends (NEMA 4) Gasket - brake ends (NEMA 4X)	8-122-501-00 8-122-502-00	2	2	2	2	2	2	2	2	2	2	2	2	2	2	2	2	2	2	2	2	2	2	2	2	2	2	2	2	2			
7P	Pipe plug (drain) Pipe plug (stainless drain)	9-33-0325-00 9-33-0325-01	1	1	1	1	1	1	1	1	1	1	1	1	1	1	1	1	1	1	1	1	1	1	1	1	1	1	1	1	1			
3	Stationary disc kit (1 disc universal 3 disc horizontal)	5-66-8354-00	1	1	1	1	1	1	1	1	1	1	1	1																				
3A	Stationary disc kit (2 disc universal)	5-66-8355-00												1	1	1	1	1	1	1	1	1	1	1	1	1								
3B	Stationary disc kit (3 disc vertical)	5-66-8356-00																																
4	Friction disc kit	5-66-8462-00	1	1	1	1	1	1	1	1	1	1	1	1	1	1	1	1	1	1	1	1	1	1	1	1	1	1	1	1	1			
4A	Stabilizing spring	8-161-505-00	2	2	2	2	2	2	2	2	2	2	2	2	2	2	2	2	2	2	2	2	2	2	2	2	2	2	2	2	2			
4DP	Disc pack kit (1 disc) Disc pack kit (2 disc) Disc pack kit (3 disc)	5-66-8601-00 5-66-8602-00 5-66-8603-00	1	1	1	1	1	1	1	1	1	1	1	1	1	1	1	1	1	1	1	1	1	1	1	1	1	1	1	1	1			
16	Hub (5/8 bore) Hub (7/8 bore) 3 disc (7/8 bore)	5-16-5150-00-01-B 5-16-5150-00-01D 5-16-5153-01	1	1	1	1	1	1	1	1	1	1	1	1	1	1	1	1	1	1	1	1	1	1	1	1	1	1	1	1	1			
2	Endplate assembly	1 & 2 disc (NEMA 2 & 4) 1 & 2 disc (NEMA 4X) 3 disc (NEMA 2 & 4) 3 disc (NEMA 4X)	5-02-5035-00 5-02-5039-00 5-02-5036-00 5-02-5040-00	1	1	1	1	1	1	1	1	1	1	1	1	1	1	1	1	1	1	1	1	1	1	1	1	1	1	1	1	1		
2A	Pipe plug - external lead holes Pipe plug - stainless (ext. lead holes)	9-33-0914-00 9-33-0624-00	1	1	1	1	1	1	1	1	1	1	1	1	1	1	1	1	1	1	1	1	1	1	1	1	1	1	1	1	1			

* Certain multiple friction disc model numbers require a single stabilizer clip (D1) added to each friction disc. If your particular brake model has this clip on the discs, as received, it must be replaced whenever the friction disc is replaced. This clip is included as part of the friction disc kit 5-66-8462-00.

Support Plate Assembly



For DC coil/Solenoid parts refer to Instruction Sheet 8-078-950-00

Solenoid and Coil Assembly

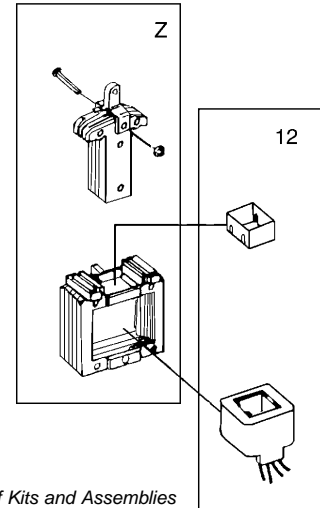

TABLE 2
Components of Support Plate and Coil Assembly

Item	Description	Part Number ↓	Torque (lb-ft)			
			1.5 & 3	6 & 10	15 & 20	25
Support Plate Assy. (Items M through Y and EA) →			5-42-5567-00	5-42-5568-00	5-42-5569-00	5-42-5569-00
6	Bearing	8-006-501-00	1	1	1	1
8	Solenoid lever	8-008-504-01	1	1	1	1
8R	Retaining ring	9-03-0057-00	1	1	1	1
8W	Spacer	9-45-0168-00	2	2	2	2
11N	Torque adjustment nut	9-40-3928-00	2	2	2	2
10	Wear adjustment screw	9-17-8420-00	2	2	2	2
11	Pressure spring	9-70-1215-00	2			
	Pressure spring	9-70-1523-00		2		
	Pressure spring	9-70-1524-00			2	2
11W	Spring washer	9-46-0010-00		4	4	4
17	Lever arm and stop nut assembly	5-17-5011-00	1	1	1	1
26	Bearing pin	9-29-4826-00	1	1	1	1
29A	Plunger stop	8-094-503-00	1	1	1	1
126	Support plate and spring stud assembly	5-26-5021-00	1	1	1	1
131	Pivot pin	9-29-4836-00	1	1	1	1
142S	Mounting screws	9-25-9013-00	3	3	3	3
AC Brakes						
Z	No. 4 solenoid kit	5-66-5047-00	1	1	1	1
12	No. 4 coil kit 60 Hz	115/230 Vac	5-66-6407-33	1		
		230/460 Vac	5-66-6409-33	1		
		115 Vac	5-66-6401-33	1		
		230 Vac	5-66-6402-33	1		
		460 Vac	5-66-6404-33	1		
	No. K4 coil kit 60 Hz	115/230 Vac	5-66-6457-33		1	
		230/460 Vac	5-66-6459-33		1	
		115 Vac	5-66-6451-33		1	
		230 Vac	5-66-6452-33		1	
		460 Vac	5-66-6454-33		1	
	No. K4 + coil kit 60 Hz	115/230 Vac	5-66-6407-23			1
		230/460 Vac	5-66-6409-23			1
		115 Vac	5-66-6401-23			1
		230 Vac	5-66-6402-23			1
		460 Vac	5-66-6404-23			1
	No. M4 + coil kit 60 Hz	115/230 Vac	5-66-6457-23			1
		230/460 Vac	5-66-6459-23			1
		115 Vac	5-66-6451-23			1
		230 Vac	5-66-6452-23			1
		460 Vac	5-66-6454-23			1
575 Vac	5-66-6455-23			1		
CC	Brake release interlock switch (optional)	5-57-5526-00	1	1	1	1

TABLE 3
Contents of Kits and Assemblies

Letter Designation	Kit Description
A	Coupler brake shaft kit 5/8" shaft (5-66-8865-00) 7/8" shaft (5-66-8867-00) 3 disc 7/8" shaft (5-66-8869-00) 1 – Hub and set screw assembly 1 – Ball bearing 1 – Housing retaining ring 1 – Brake shaft 1 – Brake shaft key
3	Stationary disc kit (5-66-8354-00) 1 – Stationary disc
3A	Stationary disc kit (5-66-8355-00) 2 – Stationary discs with springs
3B	Stationary disc kit (5-66-8356-00) 3 – Stationary discs with springs
4	Friction disc kit (5-66-8462-00) 1 – Friction disc
4A	2 – Stabilizing springs (for 1-1/2-6 lb-ft brake use only)
4DP	Disc pack kit (5-66-860X-00) 1,2 or 3 – Friction disc(s) 1,2 or 3 – Stationary disc(s) 2 – Stabilizing springs (for 1-1/2-6 lb-ft brake use only) 3,6 or 9 – Stationary disc separator springs
Z	No. 4 solenoid kit (5-66-5047-00) 1 – Plunger 1 – Solenoid link 1 – Frame 1 – Solenoid link cap screw 1 – Solenoid link nut 3 – Solenoid mounting screws
12	No. 4 AC coil kit (5-66-64XX-X3) Coil Top Plunger guide Wire nut
CC	Brake release interlock switch (5-57-5526-00) 1 – Microswitch 1 – Mounting bracket 2 – Bracket mounting screws 2 – Switch mounting screws 2 – Lead wire assembly