

## Installation and Service Instructions for 56,600 Series (rev. A) Manual Adjust Brakes

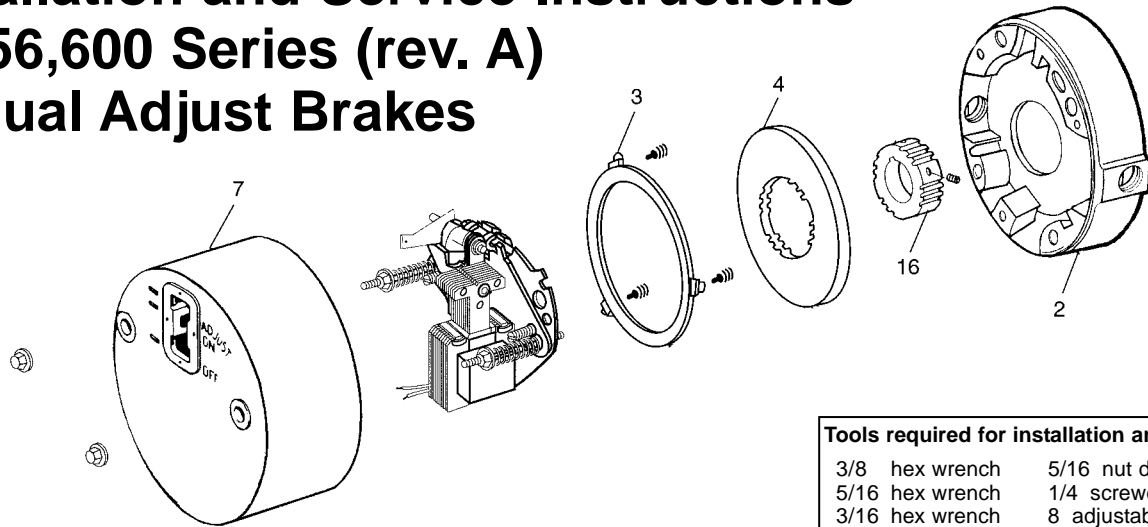

### Tools required for installation and servicing:

3/8 hex wrench	5/16 nut driver
5/16 hex wrench	1/4 screwdriver
3/16 hex wrench	8 adjustable wrench

### Typical Nameplate

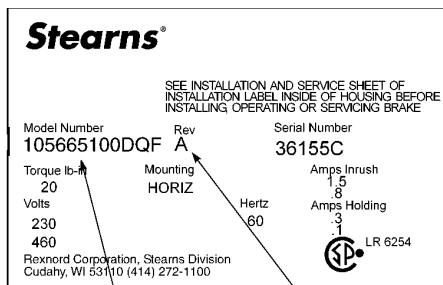

MODEL NUMBER  
will appear on brake  
nameplate

REVISION CONTROL  
(if applicable) and  
Brake Serial Number

### IMPORTANT

Please read these instructions carefully before installing, operating, or servicing your Stearns Brake. Failure to comply with these instructions could cause injury to personnel and/or damage to property if the brake is installed or operated incorrectly. For definition of limited warranty/liability, contact Rexnord Industries, Inc., Stearns Division, 5150 S. International Dr., Cudahy, WI 53110, (414) 272-1100.

### Caution

1. Installation and servicing must be made in compliance with all local safety codes including Occupational Safety and Health Act (OSHA). All wiring and electrical connections must comply with the National Electric Code (NEC) and local electric codes in effect.
2. Do not install the brake in atmospheres containing explosive gases or dusts.
3. To prevent an electrical hazard, disconnect power source before

working on the brake. If power disconnect point is out of sight, lock disconnect in the *off* position and tag to prevent accidental application of power.

4. Make certain power source conforms to the requirements specified on the brake nameplate.
5. Be careful when touching the exterior of an operating brake. Allow sufficient time for brake to cool before disassembly. Surfaces may be hot enough to be painful or cause injury.
6. Do not operate brake with housing removed. All moving parts should be guarded.
7. Installation and servicing should be performed only by qualified personnel familiar with the construction and operation of the brake.
8. For proper performance and operation, only genuine Stearns parts should be used for repairs and replacements.
9. After usage, the brake interior will contain burnt and degraded friction material dust. This dust must be removed before servicing or adjusting the brake.

DO NOT BLOW OFF DUST using an air hose. It is important to avoid dispersing dust into the air or inhaling it, as this may be dangerous to your health.

- a) Wear a filtered mask or a respirator while removing dust from the inside of a brake.
- b) Use a vacuum cleaner or a soft brush to remove dust from the brake. When brushing, avoid causing the dust to become airborne. Collect the dust in a container, such as a bag, which can

### General Description

These series of brakes are spring-set, electrically released. They contain one or more rotating friction discs (4) driven by a hub (16) mounted on the motor or other shaft.

### Operating Principle

These series contain one or more friction discs (4) assembled alternately between the endplate (2) friction surface, stationary disc(s) (3) and pressure plate (also called stationary disc) (3). The stationary disc(s) are restrained from rotating by being keyed into the endplate. With the brake released, all disc pack components are free to slide axially and the friction disc(s) to rotate.

Brake release occurs when the solenoid coil is electrically energized, causing the solenoid plunger to travel a specified distance and through a lever system, overcoming the pressure spring force. This action releases the clamping force on the disc pack, thereby allowing the friction disc(s) and brake hub to rotate.

Brake sets and torque is produced when electric current to the solenoid coil is interrupted, thereby collapsing the solenoid magnetic field. The solenoid plunger returns to its original de-energized position allowing the lever arm to move forward by virtue of the compressed torque springs. This action compresses the disc pack components which applies a retarding torque to the brake hub and ultimately restores the brake to a spring-set static condition.

**Caution!** While the brake is equipped with a manual release to allow manual shaft rotation, the motor should not be run with the manual release engaged, to avoid overheating the friction disc(s).

# BRAKE MOUNTING (Manual Adjust)

**1** Place hub on motor shaft.

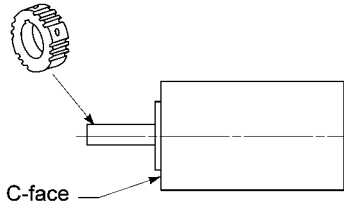

**2** Position hub on shaft as shown.

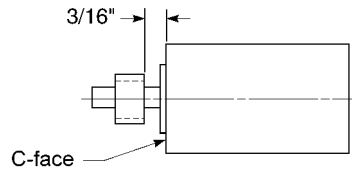

**3** Tighten set screws to motor shaft.

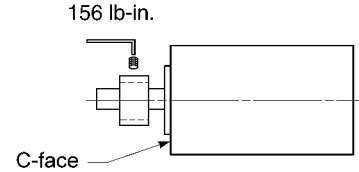

**4** Remove brake housing.

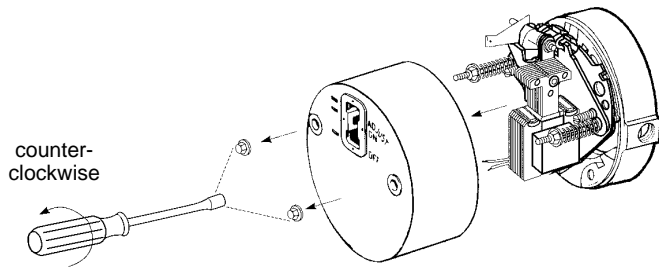

**5** Slide endplate over hub noting position of stabilizer springs, if used. (Refer to Friction Disc Replacement; view 4 and 4A.)

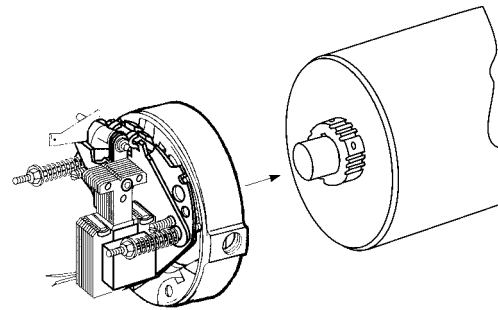

**6** Mount brake endplate to motor C-face.

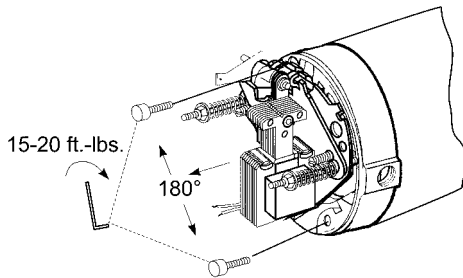

\* For vertical assembly of 20 & 25 lb-ft brakes, refer to page 5.

**7** Connect coil leadwires to power supply. Refer to nameplate for voltage rating.\*  
**Caution:** Keep wiring away from pinch points and moving components.

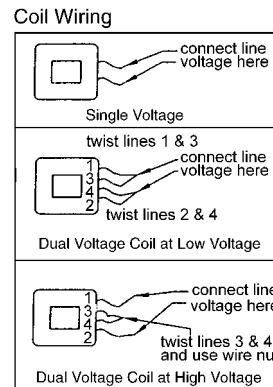

\*For DC voltages see sheet 8-078-950-00.

**8** Replace brake housing and tighten to 8 in-lb.

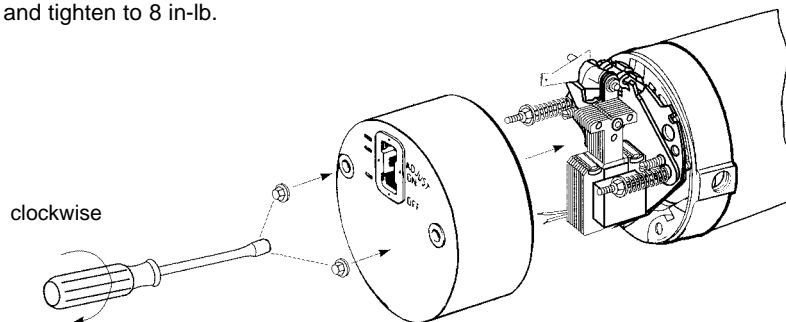

# AIR GAP ADJUSTMENT

## Series 56,600

As friction disc wear the air gap will increase. When plunger gets to the reset position, the air gap must be adjusted.

- 1** To **increase** air gap, turn adjusting screw (10) counterclockwise.

### Air Gap Settings\*

Torque (lb-ft)	56,X00 Series
1.5, 3 & 6	.385 - .030
10 & 15	.450 - .030
20 & 25	.500 - .030

\*For reference only

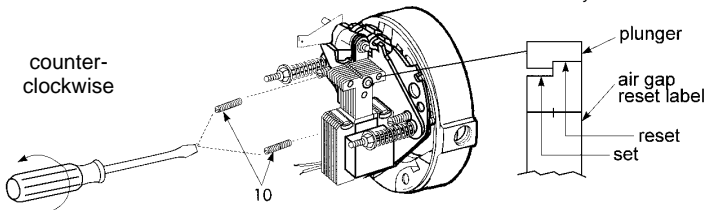

- 2** To **decrease** air gap, turn adjusting screw (10) clockwise.

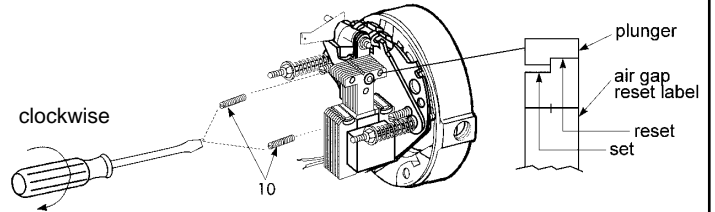

# FRICTION DISC REPLACEMENT

## Series 56,600

- 1** Remove brake housing.

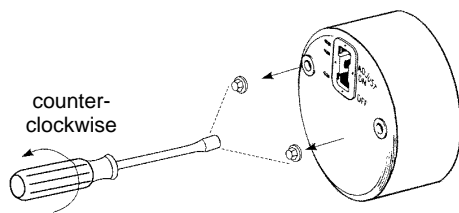

- 2** Remove support plate screws and lift support from brake.

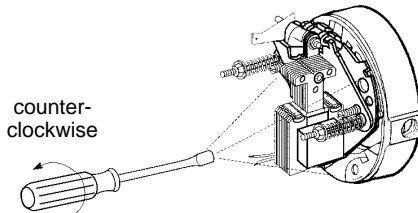

- 3** Remove and discard old friction disc.

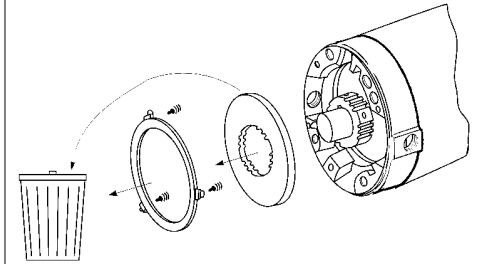

- 4** Install new friction disc(s) and stationary disc(s) as shown.

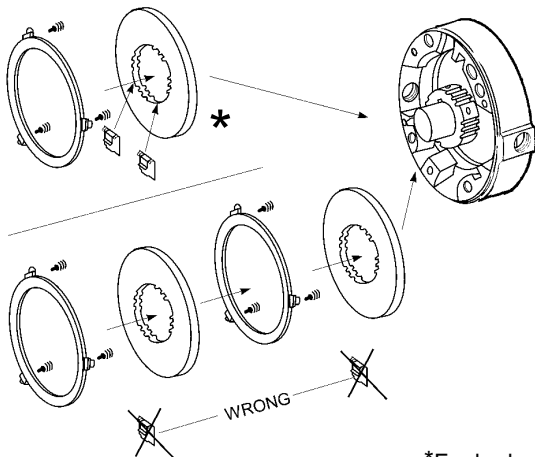

**4A**

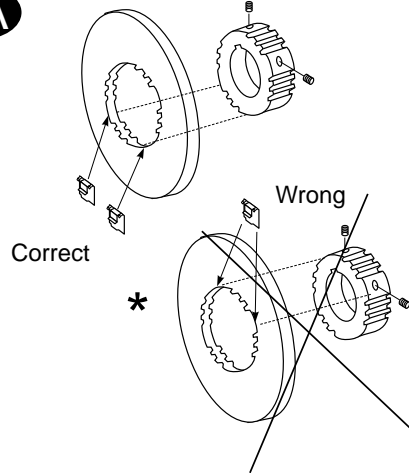

\*For brakes with vertical springs see page 5.

- 5** Reposition support plate on endplate and tighten mounting screws to 55 in-lb.

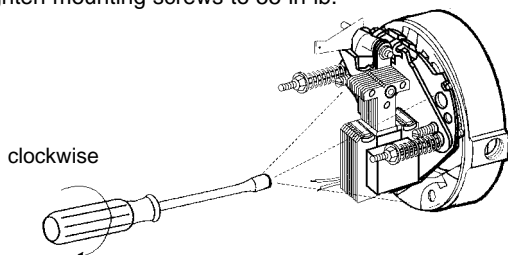

- 6** Reposition housing and tighten nuts to 8 in-lbs.

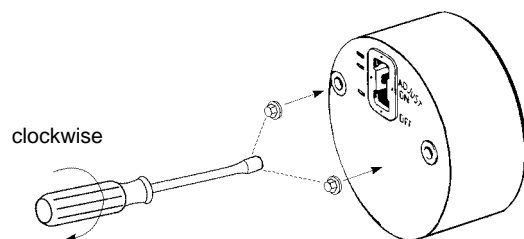

# COIL REPLACEMENT

## Series 56,600

**1** Remove brake housing.

counter-clockwise

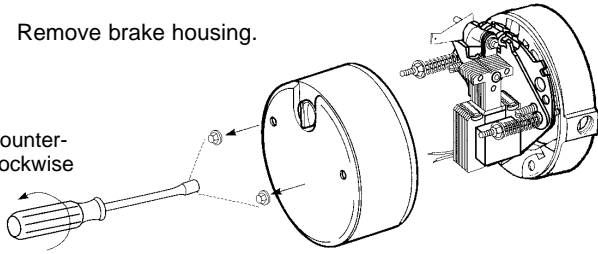

**2** Disconnect coil leadwires from power source.

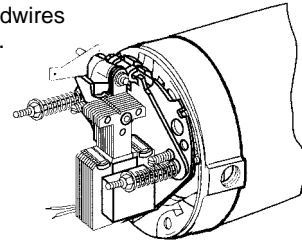

**3** Insert screwdriver between support plate and lever arm and pry forward.

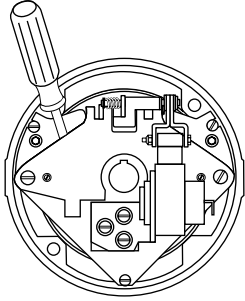

**4** Lift plunger/solenoid lever assembly out of coil.

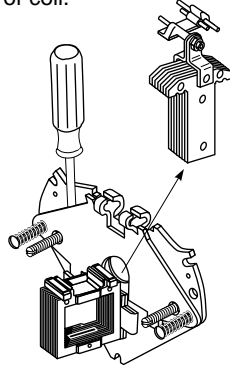

**5** Remove plunger guide.

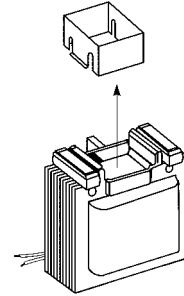

**6** Discard coil.

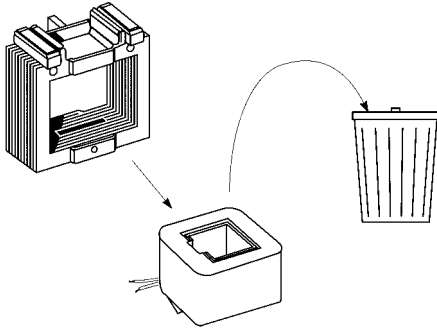

**7** A) Insert new coil. (Lead wires in same position as old coil.)  
B) Insert plunger guide.

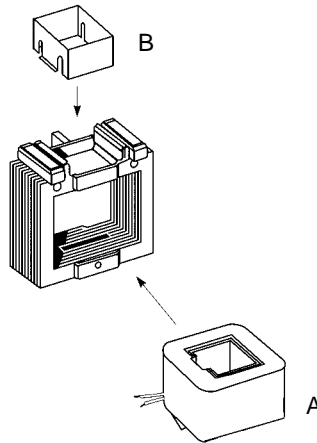

**8** A) Reinsert plunger into coil; drop pivot pin into cradle of support plate.  
B) Remove screwdriver.

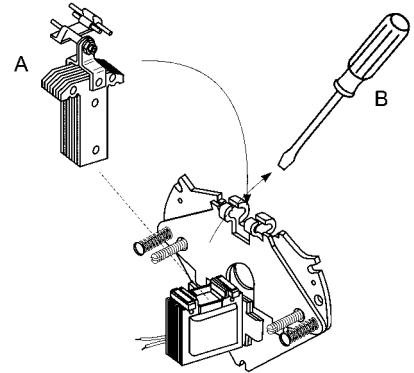

**9** Reconnect coil leadwires to power source.

### Coil Wiring

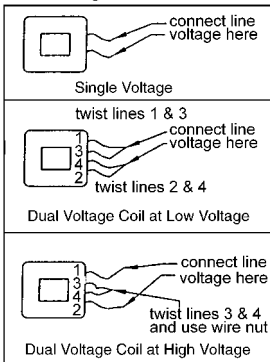

**10** Reassemble housing. Tighten to 8 in-lbs.

clockwise

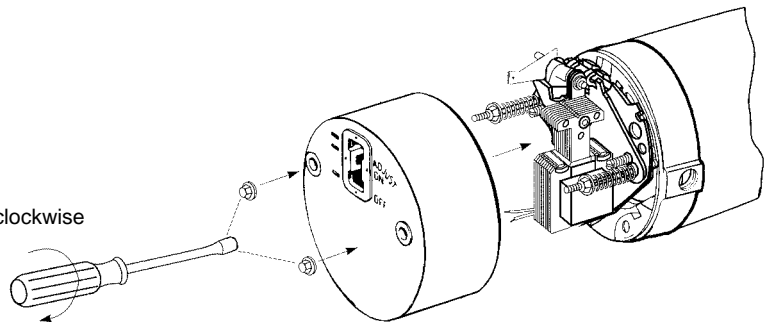

## Vertical Brake Assembly

Single disc brakes (1.5, 3 & 6 lb-ft) are universal mount and do not require separator springs. Double disc brakes (10 & 15 lb-ft.) universal mount but require separator springs which are preassembled to the stationary disc. These discs are inserted spring first into the brake. Refer to figure 5A below.

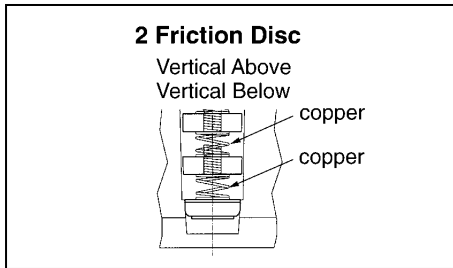

Figure 5A

## Installation Procedure for 20 and 25 lb-ft brakes if mounted vertical to motor shaft (These brakes are factory assembled for horizontal operation.)

Remove support plate by loosening the three mounting screws.

Remove stationary discs and friction discs.

Using the spring kit provided with this brake, insert three springs of identical color into each stationary disc hole. Springs are inserted from the side opposite the indent mark (see Figure 5B). Stationary disc should be placed on a clean flat surface with a clearance hole to allow the tip of the spring to extend through the bottom side of the support plate. Using the 1/8" pin provided and a hammer, drive the hold until the large coil diameter bottoms out against the disc.

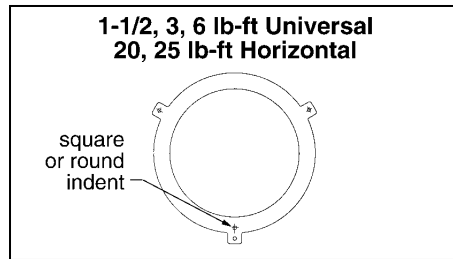

Figure 5B

Reassemble the disc pack with the stationary discs in the proper arrangement shown in Figure 5C.

Mount support plate and torque screws evenly to 55 in-lbs.

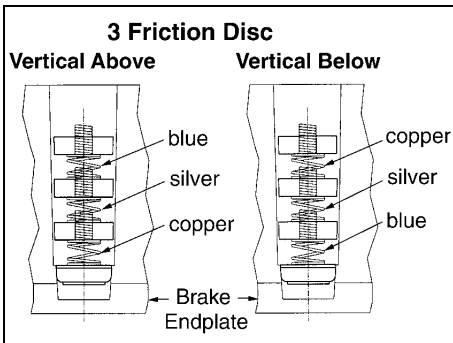

Figure 5C

## Torque Adjustment

Brake is factory set for nominal rated static torque which is maximum torque. Torque may be decreased up to 50% for increased stopping times up to 2 second stop time.

The torque on the 1-1/2 lb-ft brake may not be reduced.

Turn both adjustment nuts (11), Figure 6, equal amounts counterclockwise to decrease torque. See Table A for torque reduction permissible amounts.

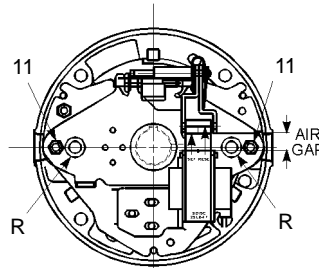

Figure 6

TABLE A

Nominal Static Torque (lb-ft)	Original Spring Height (inches)	Maximum Counter-clockwise Turns	% Torque Reduction per Turn
1-1/2	1-9/16	-	-
3	1-1/2	5-1/2	9%
6	1-1/2		
10	1-9/16		
15	1-9/16		
20	1-9/16		
25	1-1/2		

## General Maintenance

**Warning!** Any mechanism or load held in position by the brake should be secured to prevent possible injury to personnel or damage to equipment before any disassembly of the brake is attempted or before the manual release knob is operated on the brake.

Observe all cautions listed at the beginning of this manual before attempting to service brake.

## Troubleshooting

### A. If brake does not stop properly or overheats, check the following:

1. Are friction discs excessively worn, charred, or broken?
2. Hub may have become loose and shifted on shaft. Recheck set screw torque. Reposition hub if shifted.
3. With brake de-energized and housing (7) removed, check compressed length of pressure springs (11). Compare to Table values (at right) and adjust to minimum height to obtain desired stop times.
4. Is solenoid air gap adjusted correctly? See Page 3 for instructions.
5. Solenoid may not be energizing and releasing the brake. Check voltage at the coil and compare to the coil and/or nameplate voltage rating.

6. Check linkage for binding. Depress solenoid plunger down to frame surface. Movement to be without binding.
7. Brake coil should be energized at same time or prior to energization of motor, and de-energized at same time or after de-energization of motor.
8. Replace friction disc(s) when worn area is one half of original thickness.
9. Check to be sure wear adjust screws are of equal height. Measure from inboard side of support plate with depth micrometer. Turn one screw to obtain equal height.

### B. If solenoid hums, pulls in slowly, or coil burns out, check the following:

1. Solenoid plunger to frame contact surface may be excessively dented.
2. Are solenoid plunger to frame contact surfaces sticky and dirty.
3. Solenoid mounting screws may have become loose, causing frame to shift and plunger to seat improperly.

**Information required when ordering replacement parts:**

Give part number of parts or kits needed, Brake Model Number, and Brake Serial Number. The Brake Model and Serial Number may identify special brakes not covered by this parts list.

When ordering hubs, specify shaft diameter (hub bore) and keyway.

Enclosure is specified as follows:  
 NEMA 1 (formerly referred to as standard)  
 NEMA 4 (formerly referred to as DTWP dust-tight waterproof)

**Support Plate Assembly**

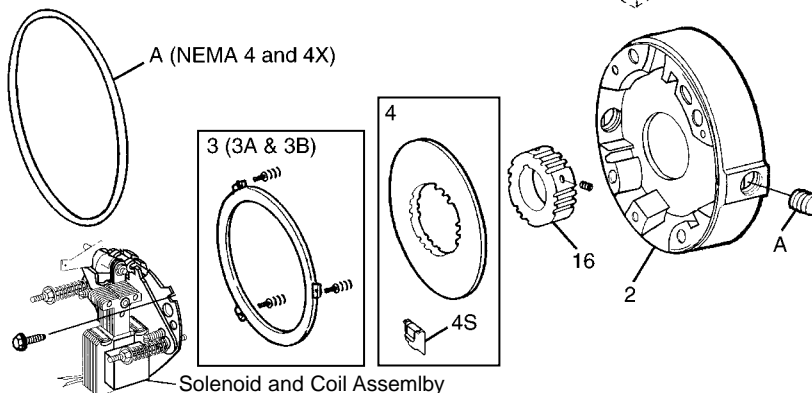
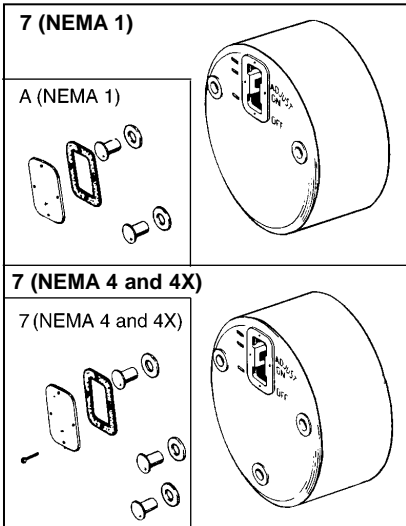
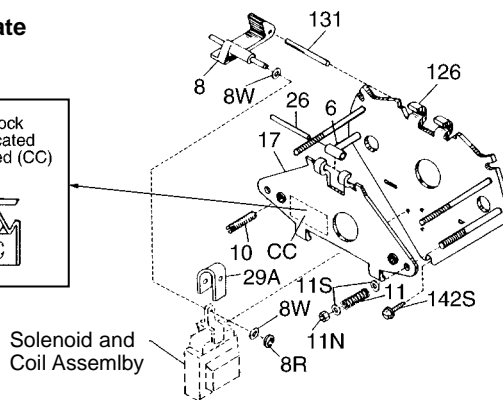
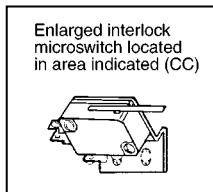

**TABLE 1**  
 Components of Standard AC or DC Brake

Item	Description	Part Number↓	Torque (lb-ft)		1.5 and 3			6			10			15			20 and 25		
			1	4	4X	1	4	4X	1	4	4X	1	4	4X	1	4	4X		
A	Hardware kit - NEMA 1 Hardware kit - NEMA 4 Hardware kit - NEMA 4X	5-66-1011-00 5-66-1012-00 5-66-1013-00	1	1	1	1	1	1	1	1	1	1	1	1	1	1			
A1	Plug/Gasket kit - NEMA 4 ** Close couple - NEMA 4X - NEMA 4 3 disc - NEMA 4X 3 disc	5-63-0532-00 5-63-0533-00 5-63-0534-00 5-63-0535-00		1	1	1	1	1	1	1	1	1	1	1	1	1			
7	Housing - NEMA 1 Housing - NEMA 4 Housing - NEMA 4X	8-007-509-20 8-007-509-21 8-007-509-23	1	1	1	1	1	1	1	1	1	1	1	1	1	1			
3	Stationary disc kit (1 disc universal 3 disc horizontal)	5-66-8354-00	1	1	1	1	1	1	1	1	1	1	1	1	1	1			
3A	Stationary disc kit (2 disc universal)	5-66-8355-00							1	1	1	1	1	1	1	1			
3B	Stationary disc kit (3 disc horizontal)	5-66-8356-00												1	1	1			
Not Shown	Vertical Spring Kit (3 disc)	5-63-0525-00												1	1	1			
4	Friction disc kit	5-66-8462-00	1	1	1	1	1	1	1	1	1	1	1	1	1	1			
4S	Stabilizing spring	8-161-505-00	2	2	2	2	2	2	2	2	2	2	2	3	3	3			
DP	Disc pack kit - 1 disc Disc pack kit - 2 disc Disc pack kit - 3 disc	5-66-8601-00 5-66-8602-00 5-66-8603-00	1	1	1	1	1	1	1	1	1	1	1	1	1	1			
16	Hub and set screw assembly 1 & 2 disc (NEMA 1)	5/8 bore 5-16-5150-00-01B 7/8 bore 5-16-5150-00-01D 1-1/8 bore 5-16-5150-00-01E	1			1			1			1							
	Hub and set screw assembly 1 disc (NEMA 4 and 4X)	5/8 bore 5-16-5151-00-01B 7/8 bore 5-16-5151-00-01D 1-1/8 bore 5-16-5151-00-01E		1	1	1	1	1											
	Hub and set screw assembly 3 disc (NEMA 1) and 2 and 3 disc (NEMA 4 and 4X)	5/8 bore 5-16-5153-00-01B 7/8 bore 5-16-5153-00-01D 1-1/8 bore 5-16-5153-00-01E							1	1	1	1	1	1	1	1	1		
2	Endplate Endplate & seal assembly	1 disc (NEMA 1) 8-002-580-01-30F 2 & 3 disc (NEMA 1) 8-002-582-01-30F 1 disc (NEMA 4) 5-02-5043-00	1			1			1			1							
	Endplate & seal assembly Endplate & seal assembly	2 & 3 disc (NEMA 4) 5-02-5044-00 1 disc (NEMA 4X) 5-02-5045-00 2 & 3 disc (NEMA 4X) 5-02-5046-00		1		1			1			1			1	1			

\* Certain multiple friction disc model numbers require a single stabilizer clip (D1) added to each friction disc. If your particular brake model has this clip on the discs, as received, it must be replaced whenever the friction disc is replaced. This clip is included as part of the friction disc kit 5-66-8462-00.

\*\* Close coupled brakes identified by 8 in the 8th digit.

**TABLE 2**  
Components of Support Plate and Coil Assembly

Item	Description	Part Number ↓	Torque (lb-ft)		1.5 & 3		6 & 10		15 & 20		25		
			1	4	1	4	1	4	1	4	1	4	
			5-42-5511-00	5-42-5512-00	5-42-5513-00	5-42-5514-00	5-42-5515-00	5-42-5516-00	5-42-5515-00	5-42-5516-00	5-42-5515-00	5-42-5516-00	
6	Bearing	8-006-501-00	1	1	1	1	1	1	1	1	1	1	
8	Solenoid lever	8-008-504-01	1	1	1	1	1	1	1	1	1	1	
8R	Retaining ring	9-03-0057-00	2	2	2	2	2	2	2	2	2	2	
8W	Spacer	9-45-0168-00	3	3	3	3	3	3	3	3	3	3	
11N	Torque adjustment nut	9-40-3928-00	2	2	2	2	2	2	2	2	2	2	
10	Wear adjustment screw	8-100-507-00	2	2	2	2	2	2	2	2	2	2	
11	Pressure spring	9-70-1215-00	2	2									
	Pressure spring	9-70-1523-00			2	2							
	Pressure spring	9-70-1524-00					2	2	2	2	2	2	
11S	Spring Washer	9-46-0010-00			4	4	4	4	4	4	4	4	
17	Lever arm and stop nut assy.	5-17-5011-00	1	1	1	1	1	1	1	1	1	1	
26	Bearing pin	9-29-4826-00	1	1	1	1	1	1	1	1	1	1	
29A	Plunger stop	8-094-503-00	1	1	1	1	1	1	1	1	1	1	
<i>Not shown</i>	Release indicator	8-028-502-00	1	1	1	1	1	1	1	1	1	1	
<i>Not shown</i>	Release spring	9-70-0809-00	1	1	1	1	1	1	1	1	1	1	
126	Support plate and spring stud assembly (2 housing studs)	5-26-5019-00	1		1		1		1		1		
	Support plate and spring stud assembly (3 housing studs)	5-26-5020-00		1		1		1		1		1	
131	Pivot pin	9-29-4836-00	1	1	1	1	1	1	1	1	1	1	
142s	Mounting screws	9-25-9013-00	3	3	3	3	3	3	3	3	3	3	
<b>AC Brakes</b>													
Z	No. 4 solenoid kit		5-66-5042-00	1	1	1	1	1	1	1	1	1	
12A	No. 4 coil kit 60 Hz	115/230 Vac	5-66-6407-33	1									
		230/460 Vac	5-66-6409-33	1									
		115 Vac	5-66-6401-33	1									
		230 Vac	5-66-6402-33	1									
		460 Vac	5-66-6404-33	1									
		575 Vac	5-66-6405-33	1									
	No. K4 coil kit 60 Hz	115/230 Vac	5-66-6457-33			1							
		230/460 Vac	5-66-6459-33			1							
		115 Vac	5-66-6451-33			1							
		230 Vac	5-66-6452-33			1							
		460 Vac	5-66-6454-33			1							
		575 Vac	5-66-6455-33			1							
	No. K4 + coil kit 60 Hz	115/230 Vac	5-66-6407-23						1				
		230/460 Vac	5-66-6409-23						1				
		115 Vac	5-66-6401-23						1				
		230 Vac	5-66-6402-23						1				
460 Vac		5-66-6404-23						1					
575 Vac		5-66-6405-23						1					
No. M4 + coil kit 60 Hz	115/230 Vac	5-66-6457-23									1		
	230/460 Vac	5-66-6459-23									1		
	115 Vac	5-66-6451-23									1		
	230 Vac	5-66-6452-23									1		
	460 Vac	5-66-6454-23									1		
	575 Vac	5-66-6455-23									1		
CC	Brake release interlock switch (optional)		5-57-5526-00	1	1	1	1	1	1	1	1	1	
<b>DC Brakes</b>													
12B	No. 4 + coil assembly	115 Vdc	5-96-6416-43	1									
		230 Vdc	5-96-6417-43	1									
	No. K4 + coil assembly	115 Vdc	5-96-6416-23			1							
		230 Vdc	5-96-6417-23			1							
No. M4 + coil assembly	115 Vdc	5-96-6466-23						1					
	230 Vdc	5-96-6467-23						1					
No. P4 + coil assembly	115 Vdc	5-96-6446-43									1		
	230 Vdc	5-96-6447-43									1		
157	Electronic DC switch kit	24/28 Vdc 115 Vdc 230 Vdc	5-57-5712-15 5-57-5716-15 5-57-5717-15										

**Solenoid and Coil Assembly**

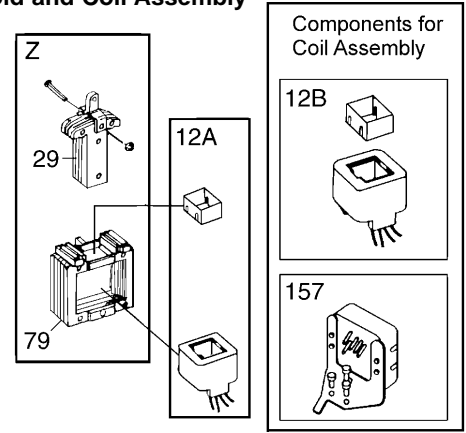

**TABLE 3**  
Contents of Kits and Assemblies

Letter Designation	Kit Description
A	Hardware kit NEMA 1 (5-66-1011-00) 2 Housing nuts 2 Housing nut flat washers 1 Release cover with clip 1 Release cover gasket
	Hardware kit NEMA 4 (5-66-1012-00) Hardware kit NEMA 4X (5-66-1013-00) 1 Endplate oil seal 1 Drain plug 3 Housing nuts 3 Housing nut O rings 1 Release cover 4 Release cover screws 1 Release cover gasket 1 Housing-to-endplate-gasket
	3 Stationary disc kit (5-66-8353-00) 1 Stationary disc
	3A Stationary disc kit (5-66-8355-00) 2 Stationary discs with springs
	3B Stationary disc kit (5-66-8356-00) 3 Stationary discs with springs
	4 & 4S Friction disc kit (5-66-8462-00) 1 Friction disc 2 Stabilizing springs (for 1-1/2-6 lb-ft brake use only)
	DP Disc pack kit (5-66-860X-00) 1, 2 or 3 Friction disc(s) 1, 2 or 3 Stationary disc(s) 2 Stabilizing springs (for 1-1/2-6 lb-ft brake use only) 3, 6 or 9 Stationary disc separator springs
	16 Hub and set screw assembly all types, all bores (5-16-515X-00) 1 Brake hub 2 Set screws
	Z No. 4 solenoid kit (5-66-5042-00) 1 Plunger 1 Solenoid link 1 Frame 1 Solenoid link cap screw 1 Solenoid link nut 3 Solenoid mounting screws
	12A 12B No. 4 AC coil kit (5-66-64XX-X3) and DC coil assembly (5-96-64XX-X3) Coil / Top Plunger guide / Wire nut
157 DC switch kit (5-57-571X-15) 1 Electronic switch 1 Mounting bracket 3 Bracket mounting screws 4 Switch mounting screws 4 Nuts 4 Lock washers 5 Crimp connectors	
CC Brake release interlock switch (5-57-5526-00) 1 Microswitch 1 Mounting bracket 2 Bracket mounting screws 2 Switch mounting screws 2 Lock washers 2 Nuts 2 Lead wire assembly	



*Rexnord Industries, Inc.  
Stearns Division  
5150 S. International Dr.  
Cudahy, Wisconsin 53110  
(414) 272-1100 Fax: (414) 277-4364*